



G3 G3 **G3**

UTILITY **ELECTRIC** VEHICLE

BOX VAN

100% electric
0g of CO²/km



SPECIFICATIONS

- For the vehicle, refer to the chassis sheet
- Maximum payload on the deck from 500 up to 700 kg*
- Capacity from 2,2m³ to 3,4m³
- Rot-proof and nonskid floorboard
- Aluminium shutter with balance spring
- Shutter handle with keys

OPTIONS AND ACCESSORIES



Side ladder carrier



Remote central locking



Roof Rack



Interior light



2nd lateral shutter



Rear shutter



Mid height shelf



*according to the battery



G3 G3 **G3**

BOX VAN

OTHER VERSIONS



Combined deck / box van



Wide box van 1,25m cargo area width

DIMENSIONS

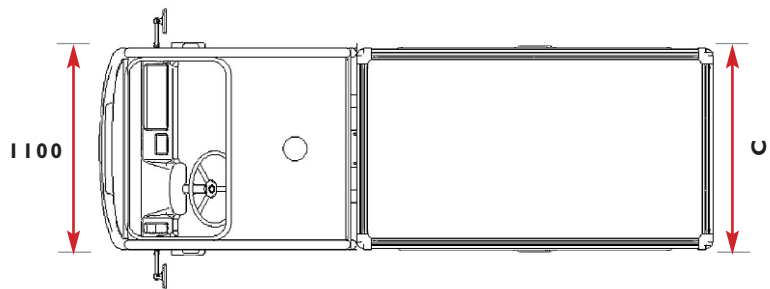
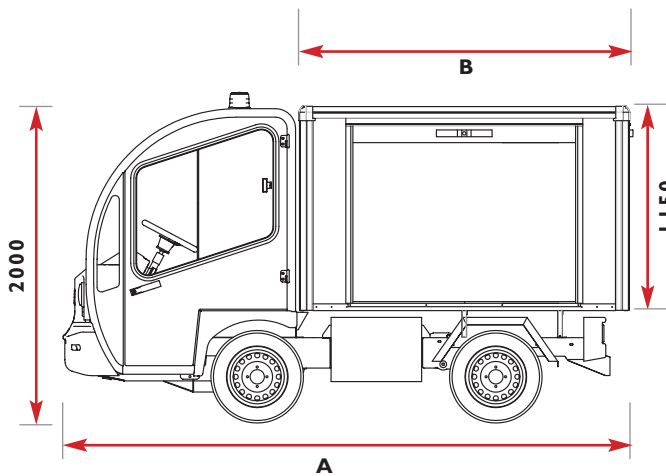

	Short version G3-S	Long version G3-L
	Vehicle Length (A) : 3 345 mm	Vehicle Length (A) : 3 845 mm
Standard Version	Box van Usable length (B) : 1 900 mm Usable width (C) : 1 020 mm Capacity : 2,2 m ³	Box van Usable length (B) : 2 400 mm Usable width (C) : 1 020 mm Capacity : 2,8 m ³
Wide version	Box van Usable length (B) : 1 900 mm Usable width (C) : 1 250 mm Capacity : 2,8 m ³	Box van Usable length (B) : 2 400 mm Usable width (C) : 1 250 mm Capacity : 3,4 m ³

Non-contractual document. Possible modification without prior notice - 09-FGN-UK-01